

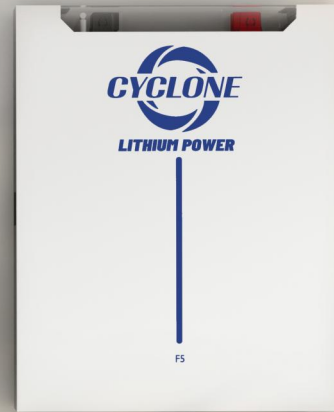

51.2V 5KWH 10KWH Wall Mounted LiFePo4 Battery



As the leading vertically integrated manufacturer of lithium iron phosphate battery systems, **Solarway Suppliers** has provided various battery solutions for nearly all kinds of ESS applications. Thanks to our self-developed core technology in cells/BMS/system design, **Solarway Suppliers** has delivered more than 138+ countries serving 100,000+ users



Facebook



Instagram



Twitter



Y N R SOLAR (PTY) LTD

Product Features



Exquisite craftsmanship
Higher specific energy,
more environmentally friendly.



Safe and reliable
Longer cycle life.



Remote Monitoring
Self-developed APP



Integrated design
Convenient installation and
higher efficiency.



Smart BMS Big
Power Smart BMS



Full Bracket Design
Full space for each
cell's best performance

Compatible With Inverter Brands

solarwaysuppliers's battery BMS supports simultaneous communication and compatible with multiple inverter brands



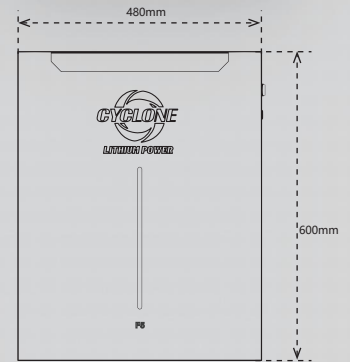
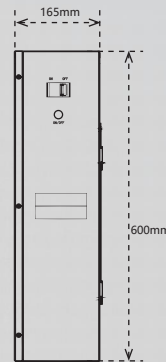
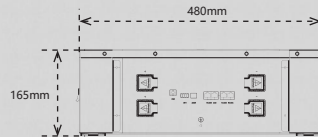
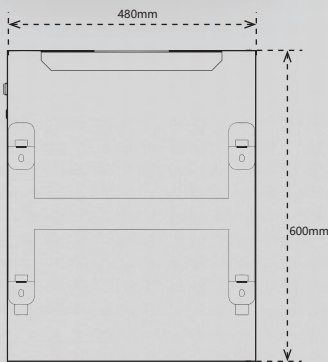
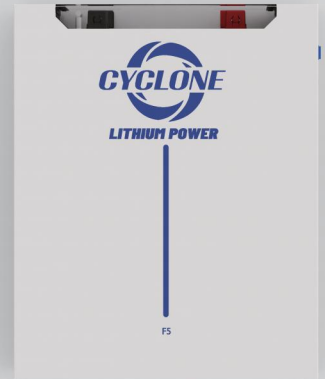
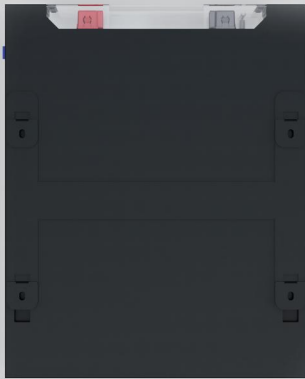

Parameters

Model No	Cyclone F5	Cyclone F10
<i>Nominal Parameters</i>		
Voltage	51.2V	51.2V
Capacity	100AH	200AH
Energy	5.12KWH	10.24KWH
Dimensions (L x W/ x H)	480x600x165mm	480x650x245mm
Weight	52KG	92KG
<i>Basic Parameters</i>		
Life time(25°C)	15 years	
Life cycles(80% DOD, 25°C)	6000Cycles	
Storage time /temperature	5 months @ 25°C: 3 months @ 35°C: 1 month @ 45°C	
Operation temperature	-20°C to 60°C @60+/-25% Relative Humidity	
Storage temperature	0°C to 45°C @60+/-25% Relative Humidity	
Lithium Battery Standard	UN38.3. MSDS.	
Enclosure protection rating	IP50	
<i>Electrical Parameters</i>		
Operation voltage	44.8-56Vdc	
Max.charging voltage	56Vdc	
Max.charging and discharging current	100A	150A
Max Power	5120W	7680W